



PTI1530C



PTI1530

Comercial • Commerciale • Commercial

PTI



CARACTERÍSTICAS

- Balanza peso-precio-importe.
- Aprobación CE de modelo con verificación de serie.
- Carcasa en ABS.
- Plato en acero inoxidable.
- Dimensiones del plato: 355x245 mm.
- Doble pantalla, en la cara del comprador y del vendedor.
- 2 versiones distintas:
 1. Sin columna (Ref. PTI1530).
 2. Con columna (Ref. PTI1530C).
- Display con retroiluminación propanable.
- Nivel burbuja.
- 32 PLU's Directos y 999 PLU's Indirectos (memorias).
- Acumula y totaliza.
- Batería interna recargable.
- Alimentación 9Vdc con adaptador AC.
- Temperatura de funcionamiento: de -10°C a +40°C.
- Salida de RS232.

CARACTÉRISTIQUES

- Balance poids-prix.
- Approbation CE du modèle avec la vignette et le carnet métrologique inclus.
- Carter en ABS.
- Plateau en acier inoxydable.
- Dimensions du plateau: 355x245 mm.
- Double écran, sur la face de l'acheteur et du vendeur.
- Deux versions distinctes:
 1. Sans colonne (Refort. PTI1530).
 2. Avec colonne (Refort. PTI1530C).
- Display rétro-éclairé.
- Niveau à bulle.
- 32 PLU's Directes et 999 PLU's Indirectes.
- Accumulation et totaux.
- Batterie interne rechargeable.
- Alimentation 9Vdc avec adaptateur AC.
- Température de fonctionnement: de -10°C à +40°C.
- Sortie RS232.

FEATURES

- Weight-Price computing scale.
- Serial CE approval with verification.
- ABS housing.
- Stainless steel pan.
- Pan size: 355x245 mm.
- Double display, in the face of the purchaser and of the solesman .
- 2 different versions:
 1. Without column (Ref. PTI1530).
 2. With column (Ref. PTI1530C).
- Backlight display.
- Bubble level.
- 32 Direct PLU's and 999 Indirect PLU's.
- Accumulation and totals.
- Internal rechargeable battery
- Power supply: 9Vdc, AC adaptor.
- Operating temperature range: from -10°C to +40°C.
- RS232 output.

Vista trasera • Vue de derrière • Rear view



Accesorio • Accessoire • Accessory

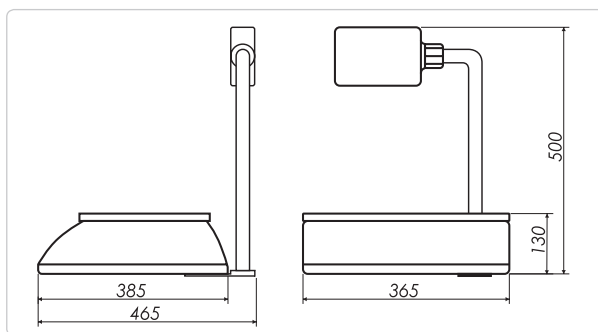

Referencia	Capacidad	Fracción	Dimensiones del plato	Dimensiones embalaje	Peso embalaje
Référence	Portée	Précision	Dimensions du plateau	Dimensions emballage	Poids emballage
Reference	Capacity (kg)	Fraction (g)	Plat dimensions (mm)	Packing dimensions (mm)	Packing weight (kg)
PTI1530	15/30	5/10	355x245	475x480x250	7
PTI1530C	15/30	5/10	355x245	475x480x250	8

Accesorios • Accessoires • Accessories

Ref.	Descripción de accesorios / Description des accessoires / Description equipment
PTI-310	Plato para pesar fruta / Plateau pour peser le fruit / Plate to weigh fruit